



HG3500S  
HG4500S

# ATV/UTV WINCH

## 140-0008 3500LBS | 4500LBS

Manual & Safety Instructions



### WARNING

Read this material before using this product.  
Failure to do so can result in serious injury. **SAVE THIS MANUAL.**





# Specifications

	HG3500S	HG4500S
<b>Rated Line</b>	3500lb (1587.5kg)	4500lb (2041kg)
<b>Motor</b>	1.2hp, 12V DC Permanent Magnet	1.4hp, 12V DC Permanent Magnet
<b>Gearing</b>	3-Stage Planetary	3-Stage Planetary
<b>Gear Ratio</b>	153:1	166:1
<b>Freespooling</b>	Cam Activated	Cam Activated
<b>Synthetic Rope</b>	5mm x 15m	5.5mm x 15m
<b>Dimensions</b>	L x W x H 285 x 100 x 106mm	L x W x H 335 x 114 x 120mm
<b>Drum Diameter</b>	31mm	50mm

	HG3500S			HG4500S		
	Line Pull (lbs./kg)	Line Speed FPM (m/min)	Motor (Amps)	Line Pull (lbs./kg)	Line Speed FPM (m/min)	Motor (Amps)
<b>Pull, Speed, Amperes, Volts (First Layer)</b>	0 (0)	23.29 (7.1)	22A	0 (0)	24.11 (7.35)	26A
	700 (318)	16.53 (5.04)	62A	1125 (511)	14.27 (4.35)	109A
	1400 (635)	12.53 (3.82)	98A	2250 (1022)	9.31 (2.84)	155A
	2100 (953)	10.17 (3.1)	141A	3375 (1534)	6.88 (2.1)	196A
	2800 (1270)	7.57 (2.31)	184A	4500 (2045)	5.41 (1.65)	238A
	3500 (1581)	6.43 (1.96)	230A			

	HG3500S		HG4500S	
Layer	Rated Line Pull (lbs./kgs)	Total Rope On Drum (ft/m)	Rated Line Pull (lbs./kgs)	Total Rope On Drum (ft/m)
<b>1</b>	3500 (1581)	8.85 (2.7)	4500 (2041)	7.22 (2.2)
<b>2</b>	2561 (1162)	19.22 (5.86)	3700 (1678)	16.08 (4.9)
<b>3</b>	2234 (1013)	31.11 (9.48)	3200 (1451)	26.57 (8.1)
<b>4</b>	1981 (899)	44.52 (13.58)	2800 (1270)	39.37 (12)
<b>5</b>	1779 (807)	50.0 (15.2)		

## Warning Symbols and Definitions

	This is the safety alert symbol. It is used to alert you to potential personal injury hazards. Obey all safety messages that follow this symbol to avoid possible injury or death.
	Indicates a hazardous situation which, if not avoided, will result in death or serious injury.
	Indicates a hazardous situation which, if not avoided, could result in death or serious injury.
	Indicates a hazardous situation which, if not avoided, could result in minor or moderate injury.
	Addresses practices not related to personal injury.

Symbol	Property of Statement
	Wear heavy-duty, cut- and abrasion-resistant leather gloves
	Wear ANSI-approved safety glasses
	Cut or sever hazard
	Roller entanglement hazard
	Hot surface burn hazard
	Fire hazard
	Caustic chemical hazard from battery acid
	Explosion hazard
	Do not loop the synthetic rope around object and hook onto itself
	Do not place finger(s) through hook. Fingers may be caught and get pulled into fairlead or drum
	Pull hook using strap only

Symbol	Property of Statement
	Do not use winch in overwind orientation. (Synthetic rope enters/exits at the top)
	Use winch only in underwind orientation. (Synthetic rope enters/exits at the bottom)
<b>VDC</b>	Volts Direct Current
<b>A</b>	Amperes
<b>CCA</b>	Cold Cranking Amperes
<b>HP</b>	Horsepower
<b>fpm</b>	Feet Per Minute
<b>mpm</b>	Meters Per Minute
<b>RPM</b>	Revolutions Per Minute
<b>IP</b>	International Protection rating classifies the degrees of protection provided against the intrusion of solid objects, dust, accidental contact, and water .
<b>G8</b>	Grade 8 is a fastener strength rating.

# Important Safety Information



**WARNING! Read all instructions.**

**Failure to follow all instructions may result in fire, serious injury and/or DEATH.**

The warnings and precautions discussed in this manual cannot cover all possible conditions and situations that may occur. It must be understood by the operator that common sense and caution are factors which cannot be built into this product, but must be supplied by the operator.

## Installation Precautions



1. Do not wear loose clothing or jewellery, as they can be caught in moving parts.  
Non-skid footwear is recommended.  
Wear restrictive hair covering to contain long hair.
2. Wear ANSI-approved safety goggles and heavy-duty leather work gloves during installation.
3. Before installation confirm that area is clear of fuel lines, brake lines, electrical wires, gas tanks or any other component which could be damaged during drilling.
4. Mounting location and hardware must support winch and load.
5. Use supplied power cords and synthetic rope listed in manual only. Do not use thinner/longer cables or link multiple cables together.
6. Do not route electrical cables near sharp edges or parts that will move or become hot.
7. Ventilate area well before and while working on battery. Explosive invisible hydrogen gas can accumulate and then explode when ignited by a spark from the battery connection.
8. Only connect to a clean, corrosion free battery.
9. Do not lean over or come in contact with battery while making connections.
10. Remove all metal jewellery before working near battery.
11. Connect red wire to positive battery terminal and black wire to negative battery terminal.
12. Insulate all exposed wiring and terminals after installation.
13. Install winch and fairlead in underwind orientation, so that the synthetic rope enters and exits the winch at the bottom of the drum.

# Operation Precautions



1. Do not exceed load capacity. **Be aware of dynamic loading!** Sudden load movement may briefly create excess load causing product failure.
2. **Do not maintain power to the winch if the motor stalls.** Verify load is within rated capacity for the steel rope layer, see Specifications on page 2. Make sure the battery is fully charged. Use double line rigging whenever possible, see Double Line Rigging on page 11.
3. Wear ANSI-approved safety goggles and heavy-duty leather work gloves during operation.
4. Do not disengage clutch under load. Engage clutch before starting.
5. Keep clear of fairlead when operating. Do not try to guide steel rope.
6. **Do not place finger(s) through hook.** Fingers may be caught and get pulled into fairlead or drum. Use included strap to hold hook instead.
7. Stay out of the direct line that the steel rope is pulling. If it slips or breaks, it will “whiplash” along this line. Place heavy rag or carpet over steel rope span 6 feet from hook to help absorb the force released if the steel rope breaks. (See Figure A.)
13. Prevent entanglement. Do not wear loose clothing or jewelry, as they can be caught in moving parts. Non-skid footwear is recommended. Wear restrictive hair covering to contain long hair.
14. Disconnect battery cables before working near the Steel Rope, drum, fairlead or load, to prevent accidental starting.
15. Inspect before every use; do not use if damaged or parts loose. Examine the winch for structural cracks, bends, damage, frayed or kinked steel rope, and any other conditions that may affect the safe operation of the winch. Do not use the winch even if minor damage appears. A kink permanently weakens the steel rope, even after it is straightened out; kinked steel rope can fail suddenly and must not be used.
16. Keep steel rope straight to avoid kinking the steel rope. The illustrations below show how a kink forms and how to prevent kinking.

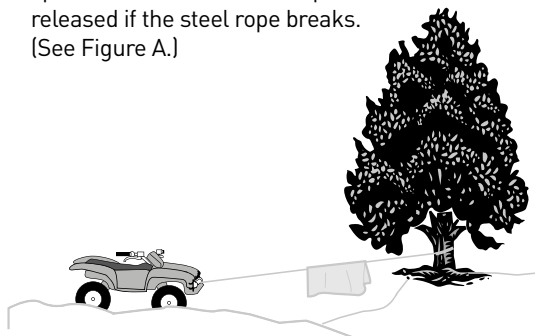
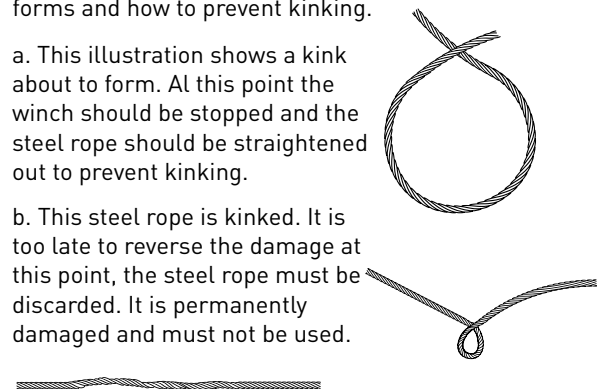

Figure A: Whiplash Dampening Blanket or Rug

8. Do not use for lifting or moving people.
9. Use a spotter to assist you in ensuring that it is safe to operate the winch. Make sure the spotter is out of the way of the vehicle and the steel rope before activating the winch.
10. Do not use the hand crank, if equipped, to “assist” the winch.
11. Do not use vehicle to pull on the Steel Rope and “assist” the winch.
12. Use as intended only. Do not lift items vertically or use for aircraft purposes.
17. Keep children and bystanders away while operating. Distractions can cause you to lose control



The unstretched parts will take more load and can fail suddenly before the rope reaches its capacity. This steel rope must be discarded and not be used.

A kink permanently weakens the steel rope, even after it is straightened out; kinked steel rope can fail suddenly and must not be used.

18. Stay alert, watch what you are doing and use common sense when operating. Do not use a winch while you are tired or under the influence of drugs, alcohol or medication. A moment of inattention while operating winches may result in serious personal injury.
19. Do not overreach. Keep proper footing and balance at all times. This enables better control of the winch in unexpected situations.
20. Hook onto the object using a pulling point, tow strap or chain. Do not wrap the steel rope around the object and hook onto the steel rope itself. This can cause damage to the object being pulled, and kink or fray the steel rope.
21. **Do not use a Recovery Strap while winching.** They are designed to stretch and can suddenly whip back towards the operator during a winching operation.
22. Secure load after moving.  
NO LOCKING MECHANISM.
23. Keep at least 5 full turns of steel rope on drum. The steel rope's connection to the drum is not intended to sustain a load, without the added support from the friction of at least 5 full turns of steel rope.
24. Wrap steel rope under 500 lb. tension before use. Otherwise, steel rope may bind during operation.
25. Keep clear of steel rope, hook, and load while winching. Do not step over steel rope. **Do not push sideways against steel rope under tension; steel rope might break under this load and recoil back, striking the person pushing against it or a bystander.**
26. If steel rope begins to get entangled, stop winch immediately and release steel rope using switch.
27. Only winch with the winching vehicle's transmission in neutral. Winching with a vehicle's transmission in gear or park may damage the transmission. A vehicle's transmission is not designed to handle that type of load.
28. Do not operate the winch at extreme angles. Do

not exceed the angles shown in Figure B for a roller fairlead. For a hawse fairlead, the angle should be as close to straight as possible.

29. If the object to be pulled must be pulled at an

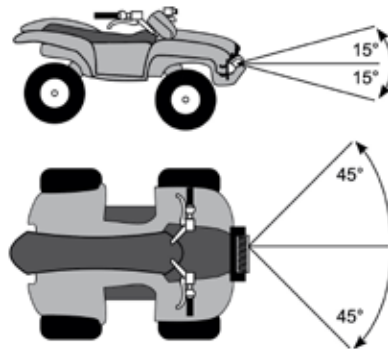

**Figure B: Roller fairlead Maximum Winching Angles**

angle in relation to the winch, use a pulley (sold separately) and an anchor point directly in front of the winch, as shown in Figure C, to keep the Steel Rope pull straight.

30. Broken strands of steel rope will be sharp. Wear

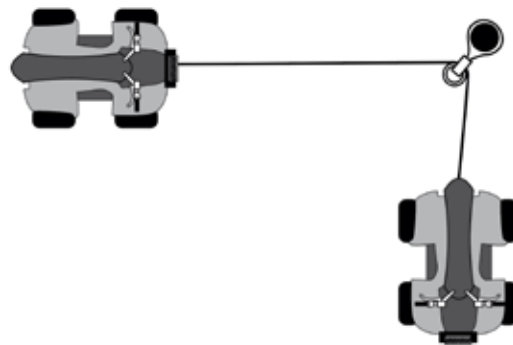
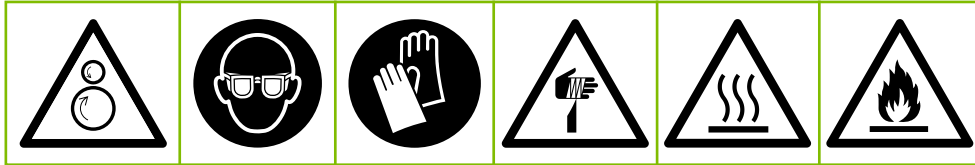

**Figure C: Pulley anchoring**

heavy-duty work gloves when handling the steel rope. Do not slide steel rope through hands, even with gloves on.

31. Winch motor will be hot during and after use. Keep clear.
32. Do not power the hook all the way into the fairlead or winch.
33. People with pacemakers should consult their physician(s) before use. Electromagnetic fields in close proximity to heart pacemaker could cause pacemaker interference or pacemaker failure.

# Service Precautions



1. Wear ANSI-approved safety goggles and heavy-duty leather work gloves during service.
2. Disconnect power to winch and allow it to cool completely before service.
3. Use supplied power cords/synthetic rope or cables listed in manual only. Do not use thinner/longer cables or link multiple cables together.
4. Have the winch serviced by a qualified repair person using only identical replacement parts. This will ensure that the safety of the winch is maintained.
5. Maintain labels and nameplates on the winch. These carry important safety information. If unreadable or missing, Contact Canadian Tire.
6. **WARNING:** Handling the cord on this product will expose you to lead, a chemical to cause cancer, and birth defects or other reproductive harm. Wash hands after handling.



**SAVE THESE INSTRUCTIONS**

# Installation and Setup



Read the **ENTIRE IMPORTANT SAFETY INFORMATION** section at the beginning of this manual including all text under subheadings therein before set up or use of this product.

## Mounting the Winch

This winch can be mounted as below Figure D.

### WARNING:

1. Make sure that the structure used for mounting will resist the winching loads.
2. To resist the winching loads, the minimum thickness of mounting surface should be 1/4" (6mm).
3. Please use the provided hardware and do not substitute of a weaker grade.

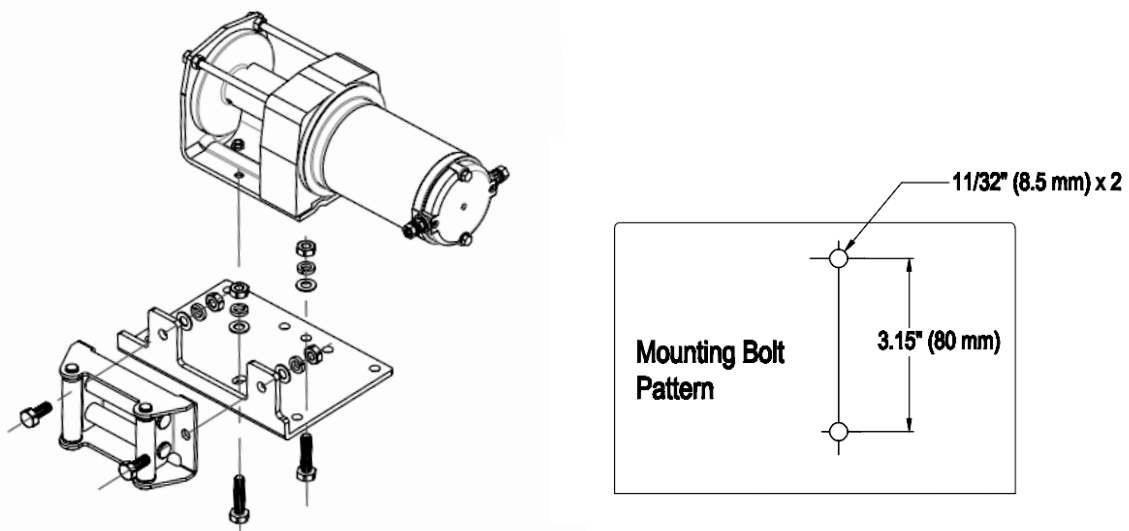

Figure D

## Mounting Winch Components

1. Mount solenoid box in proper location so that:
  - a. Winch components are close enough to each other to allow wires to be routed properly.
  - b. Vehicle component operation is not interfered with.
  - c. Vehicle components are not damaged by drilling or driving screws.
  - d. Winch components will not be damaged by stresses caused by vehicle operation.
2. Mark the locations where the screw holes will be.
3. Verify that the installation surface has no hidden components or structural pieces that will be damaged before drilling.
4. Drill pilot holes for the mounting screws.
5. Secure in place with mounting screws.



## **⚠️ WARNING**



**TO PREVENT SERIOUS INJURY FROM EXPLOSION DUE TO SPARKING AT THE BATTERY CONNECTION: Disconnect the Battery Cables before making other wiring connections.**



**TO PREVENT SERIOUS INJURY FROM LEAKING BATTERY ACID: Do not use a dirty, corroded or leaking battery. Only use a 12V automotive (or equivalent) battery, in good condition.**

1. Plan a route for the wiring from the point of the vehicle where the winch will be mounted, or used, to the battery. This route must be secure, out of the way of moving parts, road debris, or any possibility of being damaged by operation or maintenance of the vehicle.  
  
For example, you may wish to route the wires under the vehicle, attaching it to the frame using suitable fasteners. Do not attach the wires to the exhaust system, drive shaft, emergency brake cable, fuel line, or any other components which may create damage the wiring through heat or motion, or create a fire hazard.
2. If you drill through the bumper or any part of the body to route the wires, be sure to install a rubber grommet in the hole to prevent fraying of the wires at that point.
3. Route the Cables from the Solenoid to the battery and from the Solenoid to the Winch, following the precautions discussed earlier.
4. Attach the wires from the solenoid to the terminals on the winch.
5. Attach the circuit breaker to the positive terminal on the battery.
6. Attach the red battery cable to the circuit breaker.
7. Attach the black battery cable directly to the negative terminal of the battery.

### **Preparing the Synthetic Rope**

1. The synthetic rope must be properly coiled under tension to be able to support a load without damage.
2. Uncoil the synthetic rope, except for 5 full wraps.
3. Recoil the synthetic rope back into the winch under at least 500lb. of tension.

# Operation



Read the **ENTIRE IMPORTANT SAFETY INFORMATION** section at the beginning of this manual including all text under subheadings therein before set up or use of this product. The instructions that follow are basic guidelines only and cannot cover all situations encountered during use. The operator and assistants must carefully plan usage to prevent accidents.

## Clutch Operation

**CAUTION:** Do not adjust the clutch unless there is no load on the synthetic rope.

1. To engage the clutch, turn the clutch knob clockwise completely until it stops. See Figure F.
2. To release the clutch (freespool), turn the clutch knob counterclockwise completely until it stops. See Figure F.

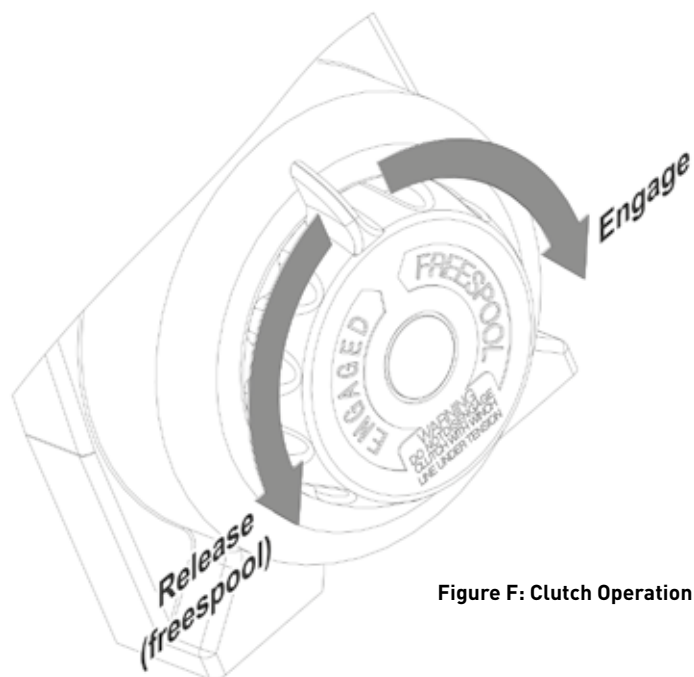

Figure F: Clutch Operation

## Basic Operation

**NOTE:** If a winch is to be used to pull a vehicle, it should optimally be rated to a single line pull at least twice the vehicle's weight.

1. Examine the synthetic rope. Do not use the winch if the synthetic rope is frayed, kinked or damaged.
2. Fully charge the vehicle's battery.
3. Check the Winch's electrical connections. All connections must be tight and clean.
4. Put the vehicle's transmission in Neutral.
5. If the vehicle where the winch is mounted is not supposed to be moved, engage the emergency brake and block the wheels using wheel chocks (sold separately).
6. To pull out the synthetic rope, move the Clutch Control to the Released position, see the instructions for your winch model under Clutch Operation section, slide the loop of the Hook Strap over the hook, then pull on the Hook Strap to pull out the synthetic rope.

**WARNING! Leave at least five full turns of synthetic rope on the drum.**

7. Hook onto the object using a pulling point, tow strap, tree strap, or chain. See Figure G.



Figure G: Using a strap anchor point



**Do not wrap the synthetic rope around the object and hook onto the synthetic rope itself.**

This can damage the object being pulled, and kink or fray the synthetic rope.

8. Attachment point must be centered in loop of hook and the hook's safety clasp must be fully closed. See Figure H.

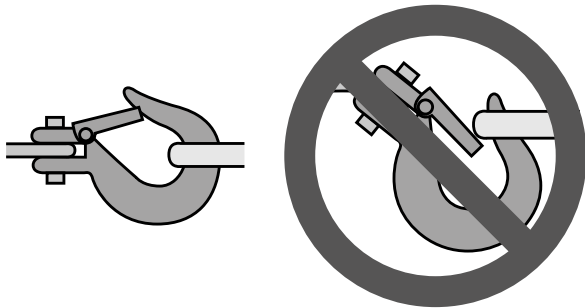

**Figure H: Correct and incorrect hook attachment**

9. Do not use a Recovery Strap while winching. They are designed to stretch and can suddenly whip back towards the operator during a winching operation.
10. Place a heavy rag or carpet (sold separately) over the synthetic rope span, 6 feet from the hook to help absorb the force released if the synthetic rope breaks.

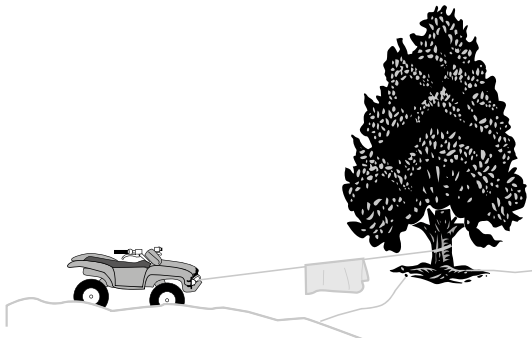

**Figure A: Whiplash Dampening Blanket or Rug**

11. Move the Clutch Control to the Engaged position, see the instructions for your winch model under Clutch Operation on page 10.

**WARNING!** Do not allow anyone to stand near the synthetic rope, or in line with the synthetic rope behind the winch while it is under power. If the synthetic rope should slip or break, it can suddenly whip back towards the winch, causing a hazard for anyone in the area. Stand well to the side while winching.

## Double Line Rigging

- a. A double line system should be used whenever possible. It reduces the load on the winch, allowing it to work longer with less heat buildup. It reduces load on the winch in two ways:
  - It utilizes the lower layers of synthetic rope that have higher capacity, and
  - It halves the load on the winch through pulley action.
- b. Connect the synthetic rope for a double line system as shown in Figure I below. Use a pulley block (sold separately) properly rated for the load to be pulled and designed to be operated with this winch's synthetic rope.

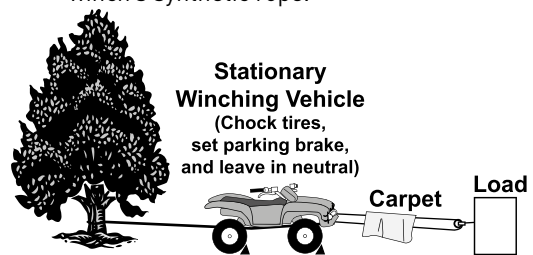

**Figure I: Double Line setup**

- c. Loop the synthetic rope around the pulley and connect to another part of the vehicle's chassis or to a separate anchor point.

**Do not anchor the Synthetic Rope back to the winch or winch mount.**

**Notes:** If anchoring the winching vehicle, only attach the anchor line to the front of the vehicle. If the anchor line is attached to the rear of the vehicle, the vehicle's frame may be damaged by the forces exerted by winching.

### **WARNING! TO PREVENT SERIOUS INJURY AND DEATH:**

Operate the winch only while you have a clear view of the winch, synthetic rope and entire winching operation. Stop winching if your view becomes obstructed.

12. Operate the controls briefly to ensure they work properly.

- The in button should retract the winch cable.
- The out button should power out the cable.

If operation is reversed, the power cables may be connected backwards.

Correct any such issue before use.

13. When it is safe to do so, use the in button to retract the synthetic rope, and winch the item as desired. Do not power the hook all the way into the fairlead to prevent damage.

14. Do not operate the winch at extreme angles. Do not exceed the angles shown in Figure B for a roller fairlead. For a hawse fairlead, the angle should be as close to straight as possible.

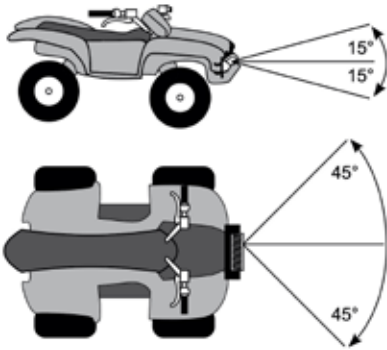

Figure B: Roller fairlead Maximum Winching Angles

15. If the object to be pulled must be pulled at an angle in relation to the winch, use a pulley (sold separately) and an anchor point directly in front of the winch, as shown in Figure C, to keep the Synthetic Rope pull straight.

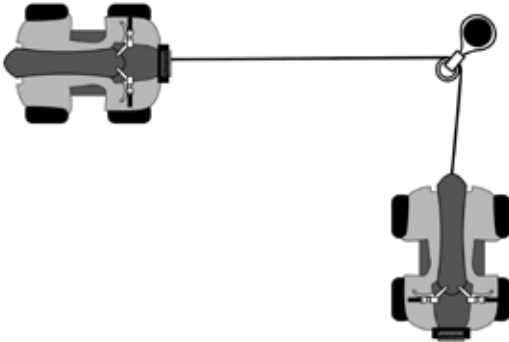

Figure C: Pulley anchoring

16. **WARNING!** Stop the winch and release tension on the synthetic rope before moving the rag or carpet placed on it.
17. When possible, keep the engine running while using this winch, to continually recharge the battery and prevent the battery from being drained so much that the vehicle cannot start. However, exercise extreme caution when working around a running vehicle and **ONLY** operate a vehicle in an outdoor area.

**NOTICE:** Do not use the winch in a constant duty application, it is designed for **INTERMITTENT USE ONLY**. Keep the duration of the pulling job as short as possible. If the motor becomes very hot to the touch, stop and let it cool down for several minutes. Do not pull for more than one minute at or near the rated load. Do not maintain power to the Winch if the motor stalls. Double Line Rigging will help prevent overloading and should be used whenever practical, see Double Line Rigging on page 11.

18. When finished pulling the load, reverse the direction of the winch just enough to release tension on the Synthetic Rope so that you can unfasten the Hook from the load and reel in the Synthetic Rope.

# Maintenance and Servicing



Procedures not specifically explained in this manual must be performed only by a qualified technician.

## ⚠ WARNING



**TO PREVENT SERIOUS INJURY FROM ACCIDENTAL OPERATION:** Disconnect the Battery Cables before performing any inspection, maintenance, or cleaning procedures.

**TO PREVENT SERIOUS INJURY FROM WINCH FAILURE:** Do not use damaged equipment. If abnormal noise or vibration occurs, have the problem corrected before further use.

## Cleaning, Maintenance, and Lubrication

1. **BEFORE EACH USE**, inspect the general condition of the winch. Check for loose hardware, misalignment or binding of moving parts, cracked or broken parts, damaged electrical wiring, corroded or loose terminals, and any other condition that may affect its safe operation. Examine the synthetic rope. Do not use the winch if the synthetic rope is frayed, kinked or damaged.
2. **AFTER USE**, wipe external surfaces of the winch with clean cloth.
3. Lubricate the synthetic rope occasionally with a light oil.
4. The winch's internal mechanism is permanently lubricated. Do not open the housing. However, if the winch is submerged, it should be opened, dried, and re-lubricated by a qualified technician as soon as possible to prevent corrosion.

## Synthetic Rope Replacement

1. Move Clutch Handle to the Released position.
2. Extend the Synthetic Rope to its full length, noting how the existing Synthetic Rope is connected to the inside of the drum.
3. Remove old Synthetic Rope and attach new assembly.

**WARNING!** Do not replace with inferior Synthetic Rope. Only use a synthetic rope rated to the same rating cited on the specification chart or better.

4. Retract Synthetic Rope onto Synthetic Rope drum being careful not to allow kinking. Refer to instructions for tensioning the synthetic rope under Preparing the Synthetic Rope on page 9.
5. Test Electric Winch for proper operation.

# Troubleshooting

Problem	Possible Causes	Likely Solutions
Motor overheats.	<ol style="list-style-type: none"> <li>1. Incorrect power cords.</li> <li>2. Winch running time too long.</li> </ol>	<ol style="list-style-type: none"> <li>1. Use only supplied power cords.</li> <li>2. Allow winch to cool down periodically.</li> </ol>
Motor does not turn on.	<ol style="list-style-type: none"> <li>1. Remote battery dead.</li> <li>2. Loose battery cable connections.</li> <li>3. Vehicle battery needs charging.</li> <li>4. Solenoid malfunctioning.</li> <li>5. Remote damaged.</li> <li>6. Defective motor.</li> <li>7. Water has entered motor.</li> <li>8. Internal damage or wear.</li> </ol>	<ol style="list-style-type: none"> <li>1. Replace Remote battery.</li> <li>2. Tighten nuts on all cable connections.</li> <li>3. Fully charge battery.</li> <li>4. Tap solenoid to loosen contacts. Apply 12 volts to coil terminals directly. A clicking indicates proper activation.</li> <li>5. Replace Remote.</li> <li>6. Check for voltage at armature port with Switch pressed. If voltage is present, replace motor.</li> <li>7. Allow to drain and dry. Run in short bursts without load until completely dry.</li> <li>8. Have technician service winch.</li> </ol>
Motor runs but Synthetic Rope drum does not turn	Clutch not engaged.	Move the Clutch Handle to the Engaged position. If problem persists, a qualified technician needs to check and repair.
Motor runs slowly or without normal power	<ol style="list-style-type: none"> <li>1. Insufficient current or voltage.</li> <li>2. Loose or corroded battery cable connections.</li> <li>3. Incorrect power cords.</li> </ol>	<ol style="list-style-type: none"> <li>1. Battery weak, recharge. Run winch with vehicle motor running.</li> <li>2. Clean, tighten, or replace.</li> <li>3. Use only supplied power cords.</li> </ol>
Motor runs in one direction only.	<ol style="list-style-type: none"> <li>1. Defective or stuck solenoid.</li> <li>2. Remote damaged.</li> </ol>	<ol style="list-style-type: none"> <li>1. Tap solenoid to loosen contacts. Repair or replace solenoid.</li> <li>2. Replace Remote.</li> </ol>



**Follow all safety precautions whenever diagnosing or servicing the tool. Disconnect power supply before service.**

# Parts List and Assembly Diagram

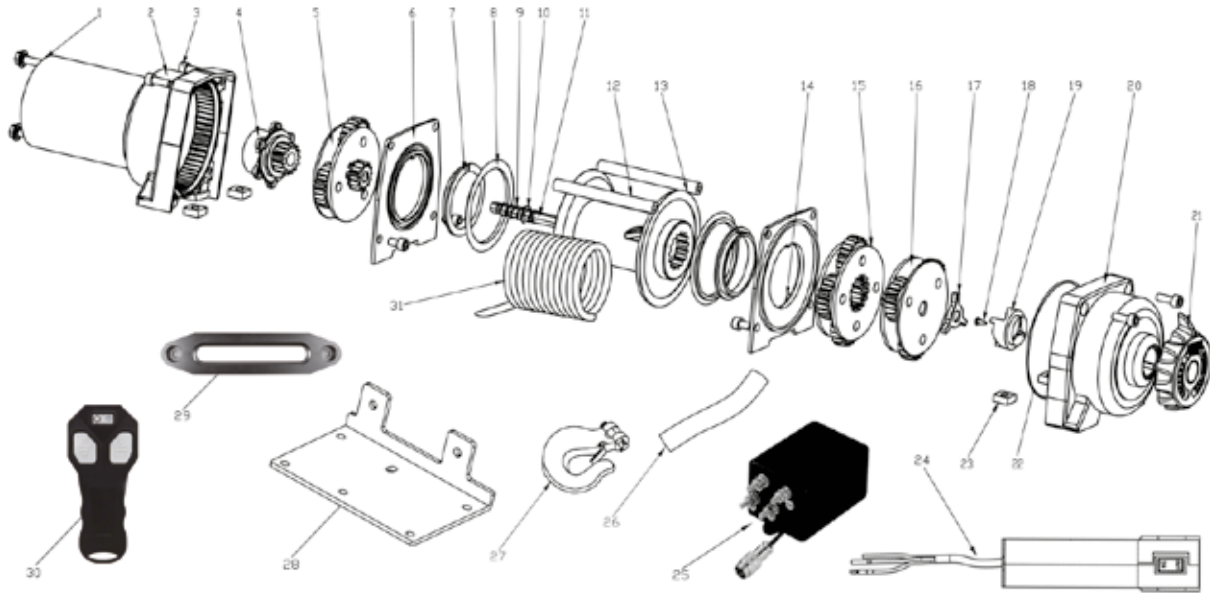

Item No.	Description	Qty
1	Motor	1
2	Gearbox	1
3	Screw M6 x 16	4
4	Brake	1
5	Planetary Gear 1	1
6	Drum Support Plate	2
7	Slide Bearing	1
8	Seal	1
9	Spline Spring	1
10	Clip	1
11	Drive Shaft	1
12	Tie Bar	2
13	Drum	1
14	Screw M6 x 10	1
15	Planetary Gear 2	1
16	Planetary Gear 3	1

Item No.	Description	Qty
17	Fork Pin	1
18	Screw	1
19	Clutch Knob Base	1
20	Gearbox	1
21	Clutch Knob	1
22	O'Ring	1
23	Base Nut M8	4
24	Pendant Controller	1
25	Control Box	1
26	Hand Saver Strap	1
27	Hook	1
28	Mounting Plate	1
29	Hawse Fairlead	1
30	Remote	1
31	Winch Rope	1

**DISTRIBUTED BY**  
Automotive Imports  
22-28 Lexton Road,  
Box Hill, Victoria,  
Australia